



schmidt
a brand of aebi schmidt

eStratos 4.0 - 12.0 m³

Spreader



The eStratos is an innovative and sustainable spreader that has been specially developed for use in demanding winter conditions. With a combination of advanced high-tech electric drive technology and proven hydraulic technology, the eStratos offers a reliable and efficient solution for winter service. The standard battery capacity allows operation with two full hoppers, making it particularly powerful and environmentally friendly.

Highlights

- **Lithium-ion battery technology with integrated heating system**, specially developed for use at low temperatures.
- The standard battery capacity enables **spreading operations with two full hoppers** without recharging.
- **Integrated charger:** Only requires a 230 V AC connection, no separate installation required at the depot.
- Proven technology with **reliable hydraulics** and **high-tech electrical engineering**.

Your benefits

- **Sustainability:** The eStratos operates almost silently and is emission-free.
- **Powerful:** The eStratos delivers full power without affecting the energy consumption of the carrier vehicle.
- **Retrofittability:** This technology is suitable for retrofitting and converts existing spreaders into completely emission-free electric spreaders.
- **Easy maintenance:** The safe 48 V DC system enables maintenance work to be carried out without special training or special safety measures.

Performance features

Sustainable electric drive

The eStratos is equipped with a front-mounted battery pack (6.2 / 12.4 / 18.6 kWh, 48 V) and an electric motor. The powerful batteries enable two spreading operations with two full hoppers each without recharging. Thanks to the integrated charger, the eStratos can be charged at any 230 V AC connection. The lithium-ion battery technology with integrated heating system is specially designed for use in temperatures down to -20°C. Thanks to the use of hydraulic technology, the eStratos achieves the same performance as conventional hydraulic machines. It retains its full performance and is not affected by the limited power of the carrier vehicle. When used on an electric carrier vehicle, the range of the carrier vehicle remains unchanged. Compared to a motorised spreader, the eStratos is significantly quieter. In addition, the safe 48 V DC system can be maintained without special training or safety measures.



Mounting and demounting systems

Maximum safety – Mounting and demount systems

The key components and sturdy construction of the spreaders are designed for maximum safety and stability, especially during mounting and demounting.

The Stratos spreaders are available in two basic variants:

- For demount legs, hooklifts and fix-mounted systems
- For the ro-ro (roll on/roll off) system.

Both variants can be demounted with a full hopper and full brine tanks.

The new ro-ro system – Even better and easier to use

The further development of the ro-ro system enabled us to make efficient improvements in trailer operation, as the 40cm increase in clearance permits the use of a trailer or a mobile warning sign. In addition, the small tipping angle and the safety belt provide maximum safety while mounting and demounting.

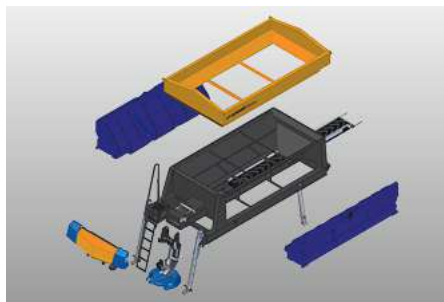
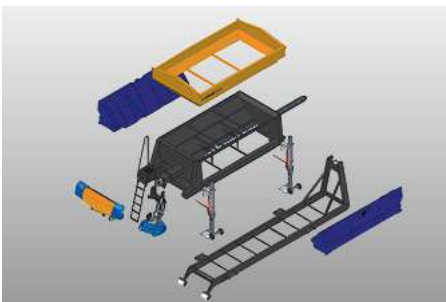

Dosage and conveyor systems

Conveyor belt system

The systems combine efficiency with safety; the conveyor belt system provides a reliable means of practical every day applications. The integrated conveyor belt is fibre-reinforced, and its V-profile ensures even transportation of the spreading material, while a stainless steel guide plate makes it possible for the belt to glide at full surface contact and minimum friction.

The precise dosage of all commercially available spreading materials is enabled by the accurately adjustable belt speed as well as a feed gate. The feed gate is equipped with an integrated lump-crushing function to ensure a flawless spreading operation; lumps are broken up at constant pressure, preventing stones and foreign particles from blocking or damaging the system. The constant feed rate allows for high dosing accuracy, irrespective of the spreading material's moisture content, while fitted chains ensure the controlled delivery of the spreading material to the chute. The optimised belt cleaning system prevents salt from running onto the truck's loading platform, improving the vehicle's ease of maintenance. The lateral sealing between the hopper and the conveyor belt by vertical belt wipers adds to the simplified maintenance required.



Auger system

The basic component of the auger system is a Flex auger with two-stage pitch. It is a cold-formed spiral with an open structure that allows for effort-saving transport at low breakaway torque. A variable thread ensures even discharge of the hopper, having a direct positive effect on the centre of gravity of the truck's spreader. Our new dosing disc achieves even dosage, which is guaranteed by a closed-loop control circuit. Meanwhile, continuous target-to-actual comparisons ensure accurate and constant speed of the system. A cover fitted as standard relieves the auger of the spreading material's load, noticeably increasing its service life. The auger system is driven by a high-torque hydraulic motor and ensures safe and reliable start-up.

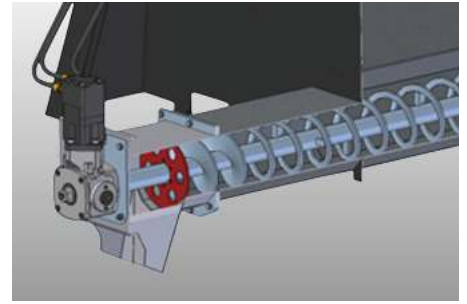

Pre-wet equipment

The pre-wet equipment is accurately adapted to the hopper size, the capacity of which has been increased, permitting an individually adjustable pre-wet salt admixture of FS 25 to FS 35. The laterally situated liquid tanks with integrated baffles are made of impact-proof and cold-resistant polyethylene. The point of intake is located at the centre of the tank, which permits trouble-free operation even in challenging hilly or mountainous regions. The integrated level indicator enables drivers to always keep track of the spreading material consumption, while the stainless steel filling and drain connection ensures reliable filling, which is considerably accelerated due to the integrated valve-filter combination, large duct cross-sections and maximum user friendliness. When switching on the brine (FS 30), the dry material is automatically reduced and the distribution system settings are optimised in accordance with the change in composition of the de-icing agent. The system achieves a high level of accuracy, thanks to integrated sensors for comparison of the actual versus the target value of the control loops.

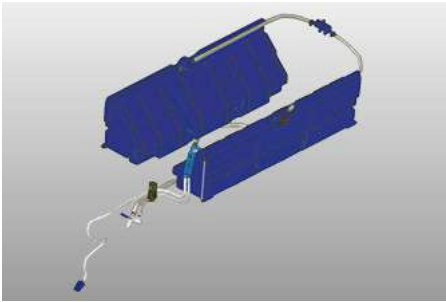

Distribution systems

Premium distribution system

In order to apply the spreading material as efficiently as possible, we have advanced our distribution systems to achieve the best possible material flow by integrating a PE chute and optimising the outlet angle of our mixing system. This is enabled due to the path of the spreading material, which is transported via the Premium mixing system to the centre of the spreading disc and is optimally distributed until it is discharged. As a result, a homogenous mixture is produced, which is ejected dynamically as a concentrated jet against the direction of travel.

Premium^{plus} distribution system

The Premium^{plus} mixing system is a further development of our Premium mixing system. In the plus variant, the mixture of salt and brine is completely prepared in a mixing chamber by means of centrifugal force and rotary movement. The rotary mixing chamber is operated electronically via the control panel and can be set to create either a symmetrical or an asymmetrical spreading pattern. The optimised scoop geometry and dimensions ensure a high level of precision over the selected spreading widths of 2-10 m, 3-12 m or 4-14 m

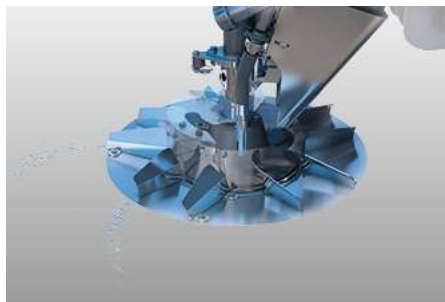
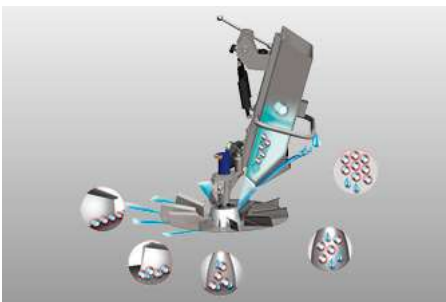

Kick-back protection on the spreading disc

On contact, the entire distribution system folds away to the back, preventing damage to the spreader.



Control and information systems

The Schmidt EvolutionLine comprises operating concepts and provides professional solutions to make de-icing easier and more efficient. Their modular structure offers a completely flexible configuration, making it possible to precisely adapt the control panels to the required needs.

ES control panel – The premium solution

The ES control panel of the Schmidt EvolutionLine is the smartphone among the control panels that meets all current and future operational requirements. The frost-proof 7" colour touchscreen display is sited in a splash-proof, sturdy housing and ensures comfortable handling, plus a long service life. The spreading density, spreading pattern and spreading width are adjusted via ergonomic click-turn control knobs, while eight illuminated push buttons operate the primary and menu-dependent functions. Equipped with optional additional components, the ES control panel can be easily upgraded to become the high-tech control centre of the spreader.

Overview of add-on modules:

- Voice confirmation for commands
- Rear camera view directly on the display
- IntelliOPS: GPRS modem for online data transfer
- GPS for position location
- Route Assistant: GPS-guided spreading operations with route guidance
- ThermoLogic: Temperature-dependent dosage

EP control panel – The extendable solution

The EP control panel is an extendable solution that can be flexibly adapted to meet the required needs. The control panel has an ergonomic design in a sturdy housing, while standard equipment comprises a frostproof, backlit display, ergonomic click-turn control knobs, plus illuminated push buttons that can be assigned individual tasks.

Overview of add-on modules:

- IntelliOPS: GPRS modem for online data transfer
- GPS for position location



IntelliOPS telematics platform

If you want to monitor, plan, control in real time, optimise or, for example, bill third parties for the activities of your eStratos, then use the digital solutions on our IntelliOPS platform. IntelliOPS supports you in the efficient use of your individual machine as well as in a network with several machines, including those of other brands. Here you can find out more about our digital solutions and how you can use them in a way that is modular and adapted to your needs.

Related products

Stratos 1.7 - 3.0 m³

Spreader



Syntos

Spreader



Stratos Combi Soliq

Combination machine



Technical data

	Stratos 40	Stratos 50	Stratos 60
Hopper			
Hopper capacity	4 m ³	5 m ³	6 m ³
Pre-wet equipment			
Tank capacity lateral tanks	1,850 / 2,400 l	1,850 / 2,400 l	2,400 / 3,000 l
Conveyor system			
Conveyor system	belt / auger	belt / auger	belt / auger
Distribution system			
Distribution systems	<p>Premium 5-zone mixing system: Spreading disc diameter: 490 mm Spreading width: 2 - 10 m</p> <p>Spreading disc: Premium 5-zone with PW50 Spreading disc diameter: 490 mm Spread. width: 2-10 m/PW50 2-6 m</p> <p>Premium 5-zone mixing system: Spreading disc diameter: 660 mm Spreading width: 3 - 12 m</p> <p>Premium 5-zone mixing system: Spreading disc diameter: 660 mm Spread. width: 3-12 m/PW50 2-8 m</p> <p>Premium 5-zone mixing system: Spreading disc diameter: 700 mm Spreading width: 4 - 14 m</p> <p>Premium 5-zone mixing system: Spreading disc diameter: 600 mm Spreading width: 2 - 10 m</p> <p>Premium plus mixing chamber: Spreading disc diameter: 660 mm Spreading width: 3 - 12 m</p> <p>Premium plus mixing chamber: Spreading disc diameter: 700 mm Spreading width: 4 - 14 m</p>	<p>Premium 5-zone mixing system: Spreading disc diameter: 490 mm Spreading width: 2 - 10 m</p> <p>Spreading disc: Premium 5-zone with PW50 Spreading disc diameter: 490 mm Spread. width: 2-10 m/PW50 2-6 m</p> <p>Premium 5-zone mixing system: Spreading disc diameter: 660 mm Spreading width: 3 - 12 m</p> <p>Premium 5-zone mixing system: Spreading disc diameter: 660 mm Spread. width: 3-12 m/PW50 2-8 m</p> <p>Premium 5-zone mixing system: Spreading disc diameter: 700 mm Spreading width: 4 - 14 m</p> <p>Premium 5-zone mixing system: Spreading disc diameter: 600 mm Spreading width: 2 - 10 m</p> <p>Premium plus mixing chamber: Spreading disc diameter: 660 mm Spreading width: 3 - 12 m</p> <p>Premium plus mixing chamber: Spreading disc diameter: 700 mm Spreading width: 4 - 14 m</p>	<p>Premium 5-zone mixing system: Spreading disc diameter: 490 mm Spreading width: 2 - 10 m</p> <p>Spreading disc: Premium 5-zone with PW50 Spreading disc diameter: 490 mm Spread. width: 2-10 m/PW50 2-6 m</p> <p>Premium 5-zone mixing system: Spreading disc diameter: 660 mm Spreading width: 3 - 12 m</p> <p>Premium 5-zone mixing system: Spreading disc diameter: 660 mm Spread. width: 3-12 m/PW50 2-8 m</p> <p>Premium 5-zone mixing system: Spreading disc diameter: 700 mm Spreading width: 4 - 14 m</p> <p>Premium 5-zone mixing system: Spreading disc diameter: 600 mm Spreading width: 2 - 10 m</p> <p>Premium plus mixing chamber: Spreading disc diameter: 660 mm Spreading width: 3 - 12 m</p> <p>Premium plus mixing chamber: Spreading disc diameter: 700 mm Spreading width: 4 - 14 m</p>
Mounting/demount system			
Mounting/demount system	RoRo / Demount legs / Hoofklift / Skip handler / Fixed-mounted	RoRo / Demount legs / Hoofklift / Skip handler / Fixed-mounted	RoRo / Demount legs / Hoofklift / Skip handler / Fixed-mounted
Control system			
Control system	EP / ES	EP / ES	EP / ES
Dimensions			
Hopper length	3,000 / 3,600 mm	3,000 / 3,600 mm	3,600 / 4,200 mm
Mounting length	3,500 / 4,100 / 4,700 mm	3,500 / 4,100 / 4,700 mm	4,100 / 4,700 mm
Hopper width	2,000 mm	2,000 mm	2,000 mm
Frame width	1,950 mm for RoRo / 2,000 mm for demount systems	1,950 mm for RoRo / 2,000 mm for demount systems	1,950 mm for RoRo / 2,000 mm for demount systems
Hopper height	1,490 / 1,600 mm	1,630 / 1,770 mm	1,650 / 1,770 mm
Weights			
Empty weight approx.	1,015 kg	1,040 kg	1,125 kg
Battery			
Battery technology	Lithium-Ion modules in IP6K7 enclosure Integrated electrical heater	Lithium-Ion modules in IP6K7 enclosure Integrated electrical heater	Lithium-Ion modules in IP6K7 enclosure Integrated electrical heater
Total capacity	6.2 kWh / 48 V (option: 12.4 kWh / 48 V) (option: 18.6 kWh / 48 V)	6.2 kWh / 48 V (option: 12.4 kWh / 48 V) (option: 18.6 kWh / 48 V)	12.4 kWh / 48 V (option: 18.6 kWh / 48 V)
Operating temperature range	-20 - 45 °C	-20 - 45 °C	-20 - 45 °C
Operating time without re-charging	2 spreading actions with standard battery	2 spreading actions with standard battery	2 spreading actions with standard battery
Charging time ca.	approx. 2 h / 6.2 kWh approx. 4 h / 12.4 kWh approx. 6 h / 18.6 kWh	approx. 2 h / 6.2 kWh approx. 4 h / 12.4 kWh approx. 6 h / 18.6 kWh	approx. 4 h / 12.4 kWh approx. 6 h / 18.6 kWh
Charging system	230 V integrated charger on the machine	230 V integrated charger on the machine	230 V integrated charger on the machine
Electro-hydraulic unit			
Power electric motor	11.7 kW / 48 V (variable speed)	11.7 kW / 48 V (variable speed)	11.7 kW / 48 V (variable speed)
Hydraulic system	110 bar / 32 l/min (integrated load sensing)	110 bar / 32 l/min (integrated load sensing)	110 bar / 32 l/min (integrated load sensing)

	Stratos 70	Stratos 80	Stratos 90
Hopper			
Hopper capacity	7 m ³	8 m ³	9 m ³
Pre-wet equipment			
Tank capacity lateral tanks	2,400 / 3,000 l	2,400 / 3,000 l	2,400 / 3,000 l
Conveyor system			
Conveyor system	belt / auger	belt / auger	belt / auger
Distribution system			
Distribution systems	<p>Premium 5-zone mixing system: Spreading disc diameter: 490 mm Spreading width: 2 - 10 m</p> <p>Spreading disc: Premium 5-zone with PW50 Spreading disc diameter: 490 mm Spread. width: 2-10 m/PW50 2-6 m</p> <p>Premium 5-zone mixing system: Spreading disc diameter: 660 mm Spreading width: 3 - 12 m</p> <p>Premium 5-zone mixing system: Spreading disc diameter: 660 mm Spread. width: 3-12 m/PW50 2-8 m</p> <p>Premium 5-zone mixing system: Spreading disc diameter: 700 mm Spreading width: 4 - 14 m</p> <p>Premium 5-zone mixing system: Spreading disc diameter: 600 mm Spreading width: 2 - 10 m</p> <p>Premium plus mixing chamber: Spreading disc diameter: 660 mm Spreading width: 3 - 12 m</p> <p>Premium plus mixing chamber: Spreading disc diameter: 700 mm Spreading width: 4 - 14 m</p>	<p>Premium 5-zone mixing system: Spreading disc diameter: 490 mm Spreading width: 2 - 10 m</p> <p>Spreading disc: Premium 5-zone with PW50 Spreading disc diameter: 490 mm Spread. width: 2-10 m/PW50 2-6 m</p> <p>Premium 5-zone mixing system: Spreading disc diameter: 660 mm Spreading width: 3 - 12 m</p> <p>Premium 5-zone mixing system: Spreading disc diameter: 660 mm Spread. width: 3-12 m/PW50 2-8 m</p> <p>Premium 5-zone mixing system: Spreading disc diameter: 700 mm Spreading width: 4 - 14 m</p> <p>Premium 5-zone mixing system: Spreading disc diameter: 600 mm Spreading width: 2 - 10 m</p> <p>Premium plus mixing chamber: Spreading disc diameter: 660 mm Spreading width: 3 - 12 m</p> <p>Premium plus mixing chamber: Spreading disc diameter: 700 mm Spreading width: 4 - 14 m</p>	<p>Premium 5-zone mixing system: Spreading disc diameter: 490 mm Spreading width: 2 - 10 m</p> <p>Spreading disc: Premium 5-zone with PW50 Spreading disc diameter: 490 mm Spread. width: 2-10 m/PW50 2-6 m</p> <p>Premium 5-zone mixing system: Spreading disc diameter: 660 mm Spreading width: 3 - 12 m</p> <p>Premium 5-zone mixing system: Spreading disc diameter: 660 mm Spread. width: 3-12 m/PW50 2-8 m</p> <p>Premium 5-zone mixing system: Spreading disc diameter: 700 mm Spreading width: 4 - 14 m</p> <p>Premium 5-zone mixing system: Spreading disc diameter: 600 mm Spreading width: 2 - 10 m</p> <p>Premium plus mixing chamber: Spreading disc diameter: 660 mm Spreading width: 3 - 12 m</p> <p>Premium plus mixing chamber: Spreading disc diameter: 700 mm Spreading width: 4 - 14 m</p>
Mounting/demount system			
Mounting/demount system	RoRo / Demount legs / Hoofklift / Skip handler / Fixed-mounted	RoRo / Demount legs / Hoofklift / Skip handler / Fixed-mounted	RoRo / Demount legs / Hoofklift / Skip handler / Fixed-mounted
Control system			
Control system	EP / ES	EP / ES	EP / ES
Dimensions			
Hopper length	4,200 mm	4,200 mm	4,200 mm
Mounting length	4,700 mm	4,700 mm	4,700 mm
Hopper width	2,000 mm	2,000 mm	2,000 mm
Frame width	1,950 mm for RoRo / 2,000 mm for demount systems	1,950 mm for RoRo / 2,000 mm for demount systems	1,950 mm for RoRo / 2,000 mm for demount systems
Hopper height	1,770 mm	1,885 mm	2,005 mm
Weights			
Empty weight approx.	1,375 kg	1,420 kg	1,455 kg
Battery			
Battery technology	Lithium-Ion modules in IP6K7 enclosure Integrated electrical heater	Lithium-Ion modules in IP6K7 enclosure Integrated electrical heater	Lithium-Ion modules in IP6K7 enclosure Integrated electrical heater
Total capacity	12.4 kWh / 48 V (option: 18.6 kWh / 48 V)	12.4 kWh / 48 V (option: 18.6 kWh / 48 V)	18.6 kWh / 48 V
Operating temperature range	-20 - 45 °C	-20 - 45 °C	-20 - 45 °C
Operating time without re-charging	2 spreading actions with standard battery	2 spreading actions with standard battery	2 spreading actions with standard battery
Charging time ca.	approx. 4 h / 12.4 kWh approx. 6 h / 18.6 kWh	approx. 4 h / 12.4 kWh approx. 6 h / 18.6 kWh	approx. 6 h / 18.6 kWh
Charging system	230 V integrated charger on the machine	230 V integrated charger on the machine	230 V integrated charger on the machine
Electro-hydraulic unit			
Power electric motor	11.7 kW / 48 V (variable speed)	11.7 kW / 48 V (variable speed)	11.7 kW / 48 V (variable speed)
Hydraulic system	110 bar / 32 l/min (integrated load sensing)	110 bar / 32 l/min (integrated load sensing)	110 bar / 32 l/min (integrated load sensing)

	Stratos 100	Stratos 120
Hopper		
Hopper capacity	10 m ³	12 m ³
Pre-wet equipment		

	Stratos 100	Stratos 120
Tank capacity lateral tanks	3,000 l	3,000 l
Conveyor system		
Conveyor system	belt	belt
Distribution system		
Distribution systems	<p>Premium 5-zone mixing system: Spreading disc diameter: 490 mm Spreading width: 2 - 10 m</p> <p>Spreading disc: Premium 5-zone with PW50 Spreading disc diameter: 490 mm Spread. width: 2-10 m/PW50 2-6 m</p> <p>Premium 5-zone mixing system: Spreading disc diameter: 660 mm Spreading width: 3 - 12 m</p> <p>Premium 5-zone mixing system: Spreading disc diameter: 660 mm Spread. width: 3-12 m/PW50 2-8 m</p> <p>Premium 5-zone mixing system: Spreading disc diameter: 700 mm Spreading width: 4 - 14 m</p> <p>Premium 5-zone mixing system: Spreading disc diameter: 600 mm Spreading width: 2 - 10 m</p> <p>Premium plus mixing chamber: Spreading disc diameter: 660 mm Spreading width: 3 - 12 m</p> <p>Premium plus mixing chamber: Spreading disc diameter: 700 mm Spreading width: 4 - 14 m</p>	<p>Premium 5-zone mixing system: Spreading disc diameter: 490 mm Spreading width: 2 - 10 m</p> <p>Spreading disc: Premium 5-zone with PW50 Spreading disc diameter: 490 mm Spread. width: 2-10 m/PW50 2-6 m</p> <p>Premium 5-zone mixing system: Spreading disc diameter: 660 mm Spreading width: 3 - 12 m</p> <p>Premium 5-zone mixing system: Spreading disc diameter: 660 mm Spread. width: 3-12 m/PW50 2-8 m</p> <p>Premium 5-zone mixing system: Spreading disc diameter: 700 mm Spreading width: 4 - 14 m</p> <p>Premium 5-zone mixing system: Spreading disc diameter: 600 mm Spreading width: 2 - 10 m</p> <p>Premium plus mixing chamber: Spreading disc diameter: 660 mm Spreading width: 3 - 12 m</p> <p>Premium plus mixing chamber: Spreading disc diameter: 700 mm Spreading width: 4 - 14 m</p>
Mounting/demount system		
Mounting/demount system	RoRo / Demount legs / Hoofklift / Fixed-mounted	RoRo / Demount legs / Hoofklift / Fixed-mounted
Control system		
Control system	EP / ES	EP / ES
Dimensions		
Hopper length	4,510 mm	4,510 mm
Mounting length	5,020 mm	4,700 mm
Hopper width	2,150 mm	2,150 mm
Frame width	2,180 mm for RoRo / 2,580 mm for demount systems	2,180 mm for RoRo / 2,580 mm for demount systems
Hopper height	2,045 mm	2,235 mm
Weights		
Empty weight approx.	1,635 kg	1,700 kg
Battery		
Battery technology	Lithium-Ion modules in IP6K7 enclosure Integrated electrical heater	Lithium-Ion modules in IP6K7 enclosure Integrated electrical heater
Total capacity	18.6 kWh / 48 V	18.6 kWh / 48 V
Operating temperature range	-20 - 45 °C	-20 - 45 °C
Operating time without re-charging	2 spreading actions with standard battery	2 spreading actions with standard battery
Charging time ca.	approx. 6 h / 18.6 kWh	approx. 6 h / 18.6 kWh
Charging system	230 V integrated charger on the machine	230 V integrated charger on the machine
Electro-hydraulic unit		
Power electric motor	11.7 kW / 48 V (variable speed)	11.7 kW / 48 V (variable speed)
Hydraulic system	110 bar / 32 l/min (integrated load sensing)	110 bar / 32 l/min (integrated load sensing)

