



 **schmidt**
a brand of aebi schmidt

eSyntos

Spreader



The eSyntos is the first electric pre-wetted salt spreader from Schmidt. The combination of high-tech electric drive technology with robust and proven hydraulic technology is perfectly suited for use in harsh winter conditions. The series is suitable for mounting on flatbeds, pick-ups or narrow-track vehicles.

Highlights

- **Lithium-ion battery technology with integrated heating system**, especially for use in low temperatures.
- Standard battery capacity is sufficient **for spreading two full hopper loads without recharging.**
- **Integrated charger.** No separate installation required at the depot, just a 230 V AC connection.

Your benefits

- **Powerful:** Full power, the eSyntos is not limited by the electrical functions of the carrier vehicle.
- **Retrofittable:** The technology is perfect for retrofitting, transforming an existing spreader into a 100% emission-free electric spreader.
- **Maintenance without special training:** Safe 48 V DC system can be maintained without special training or safety measures.

We know how important it is that your machines and equipment are always ready to deploy. **Get in touch with us** about our range of tailored services and original spare parts.



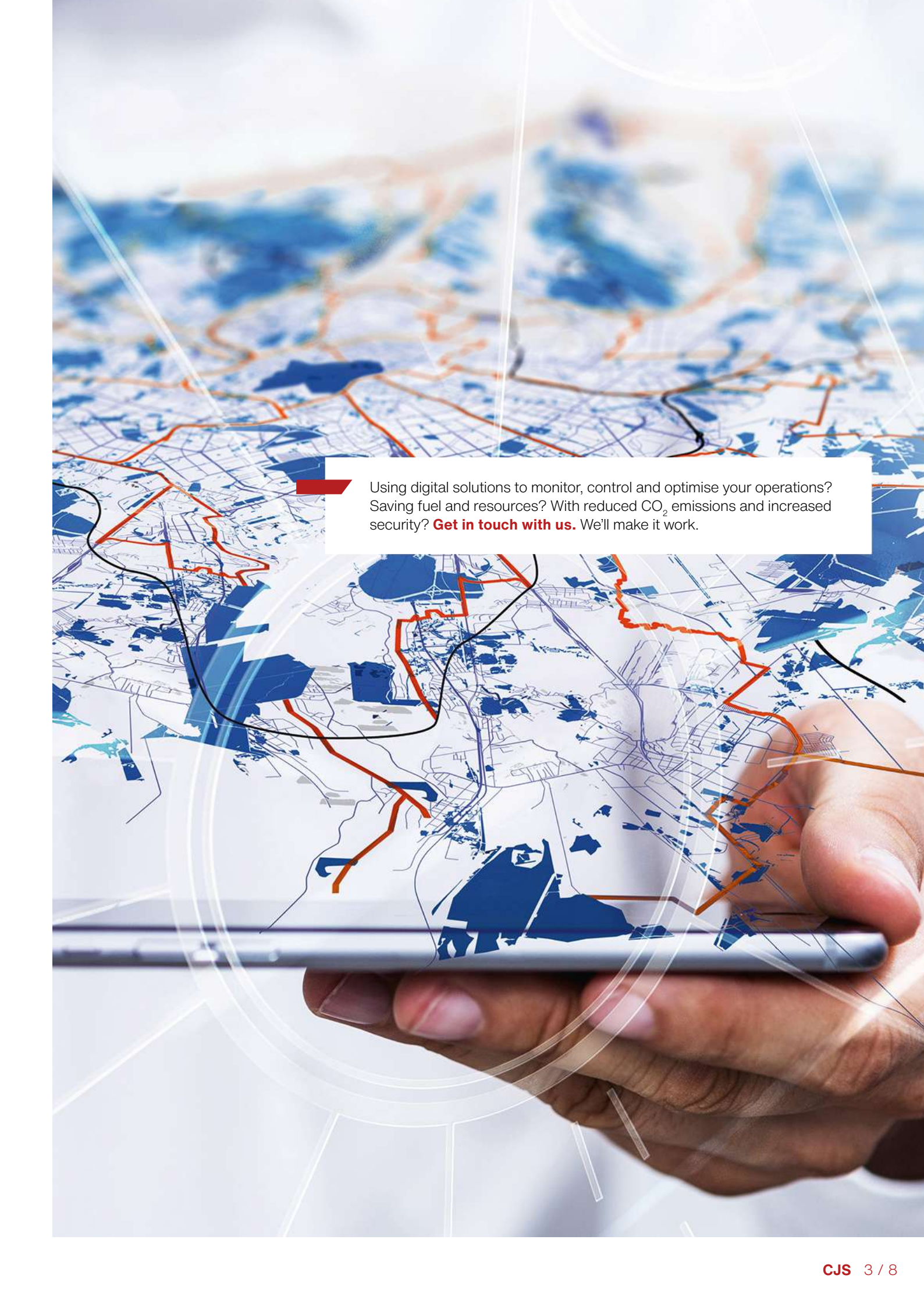

Using digital solutions to monitor, control and optimise your operations? Saving fuel and resources? With reduced CO₂ emissions and increased security? **Get in touch with us.** We'll make it work.

Performance features

Environmentally friendly electric drive

The eSyntos has a front-mounted battery pack (4.1 / 6.1 / 8.2 kWh, 48 V) and an electric motor. The powerful batteries allow two spreading operations of two full hoppers without recharging. The integrated charger allows the eSyntos to be recharged at any 230 V AC connection. The lithium-ion battery technology with integrated heating system is specially designed for use at low temperatures (down to -20°C).

The use of hydraulic technology makes the eSyntos equal to a conventional/hydraulic machine. The spreader maintains its full power and is not restricted in its performance by the usually limited power of the carrier vehicle. Moreover, when mounted on an electric carrier vehicle, the range of the carrier vehicle remains unchanged. Compared to a motor-driven spreader, the noise level is significantly lower. In addition, the safe 48 V DC system can be maintained without special training or safety measures.



Modular concept

The eSyntos is a robust spreader made of durable polyethylene, with a liquid tank integrated in the hopper which enables even emptying and contributes to a low centre of gravity. Three hopper sizes from 0.8-1.5 m³ and several different frame lengths are available.

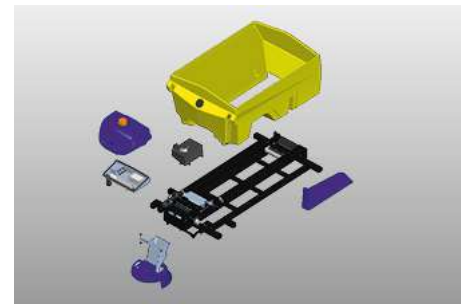

Dosage and conveyor systems

The dosing system can be either belt or auger conveyor. With the trailer version, dosing is carried out exclusively via the belt conveyor system. A V-shaped, endlessly profiled conveyor belt is used, which runs on a sliding plate and thus leaves no bearing points in the hopper. The dosing slide with an integrated lump crusher ensures high dosing accuracy. The hydraulic motor-driven auger conveyor has a variable thread which gives uniform hopper emptying.

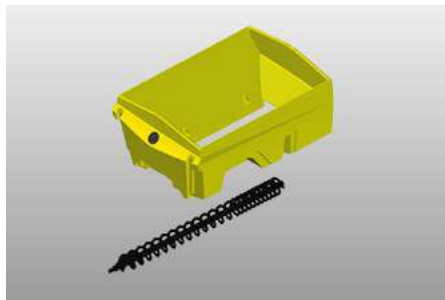
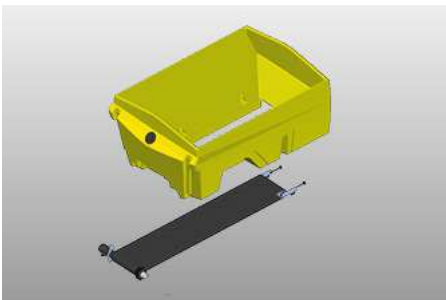

Pre-wet equipment

The spreader is equipped with an integrated all-round brine tank with a liquid level indicator and a brine pump with run-dry protection. A rear-side Storz C connection is available for filling and emptying. When switching on the brine (FS 30), the dry material is automatically reduced and the distribution system settings are optimised in accordance with the change in composition of the de-icing agent. The system achieves a high level of accuracy, thanks to integrated sensors for comparison of the actual versus the target value of the control loops.

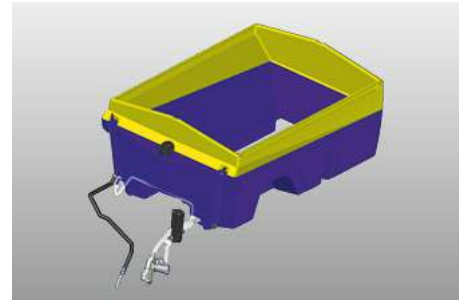

Distribution system

Spreading is carried out via a 350mm stainless steel spreading disc offering a width of 2m-6m, and the entire distribution system can be folded up and is infinitely adjustable so that the optimum distance to the ground can be set for each carrier vehicle. In combination with the EP or ES control panel, an electric spreading pattern adjustment is available as standard.



Control and information technology

Operation is via a digital full road-speed related EP control with a large, clear graphic display, easy-grip rotary knobs with click louvres and illuminated push buttons. As option, the full road-speed related ES control with 7" colour touch screen is available.



IntelliOPS telematics platform

The Syntos spreaders can be connected to the Aebi Schmidt IntelliOPS platform which provides comprehensive monitoring, selection, reporting and analysis functions. It enables rapid performance evaluation by displaying machine activity data live on a map and uses collected data to provide detailed overviews and reports to optimise operations.

Gallery



Related products

Syntos
Spreader



Stratos 0.6 - 0.8m³
Spreader





Trust in our many years of uniquely diverse experience. **Get in touch with us.** We'll find the right solution for your specific challenge.

Technical data

	eSyntos 08	eSyntos 11	eSyntos 15
Hopper			
Hopper capacity	0.8 m ³	1.1 m ³	1.5 m ³
Pre-wet equipment			
Tank capacity integrated tank	400 / 520 l	400 / 520 / 625 l	520 / 625 l
Conveyor system			
Conveyor system	belt / auger	belt / auger	belt / auger
Distribution system			
Distribution systems	Basic spreading disc: Spreading disc diameter: 350 mm Spreading width: 2 - 6 m	Basic spreading disc: Spreading disc diameter: 350 mm Spreading width: 2 - 6 m	Basic spreading disc: Spreading disc diameter: 350 mm Spreading width: 2 - 6 m
Mounting/demount system			
Mounting/demount system	Demount legs	Demount legs	Demount legs
Control system			
Control system	EP / ES	EP / ES	EP / ES
Dimensions			
Hopper length	1,450 / 1,750 mm	1,450 / 1,750 mm	1,750 / 2,050 mm
Mounting length	1,700 / 2,000 / 2,300 / 2,600 / 2,900 mm	1,700 / 2,000 / 2,300 / 2,600 / 2,900 mm	2,000 / 2,300 / 2,600 / 2,900 mm
Hopper width	1,420 mm	1,420 mm	1,420 mm
Frame width	1,400 mm	1,400 mm	1,400 mm
Hopper height	940 / 1,030 mm	940 / 990 / 1,030 / 1,070 / 1,200 mm	1,150 / 1,260 mm
Weights			
Empty weight approx.	556 kg	564 kg	607 kg
Battery			
Battery technology	Lithium-Ion modules in IP6K7 enclosure Integrated electrical heater	Lithium-Ion modules in IP6K7 enclosure Integrated electrical heater	Lithium-Ion modules in IP6K7 enclosure Integrated electrical heater
Total capacity	4.1 kWh / 48 V (option: 6.1 kWh / 48 V) (option: 8.2 kWh / 48 V)	4.1 kWh / 48 V (option: 6.1 kWh / 48 V) (option: 8.2 kWh / 48 V)	4.1 kWh / 48 V (option: 6.1 kWh / 48 V) (option: 8.2 kWh / 48 V)
Operating temperature range	-20 - 45 °C	-20 - 45 °C	-20 - 45 °C
Operating time without re-charging	2 spreading actions with standard battery	2 spreading actions with standard battery	2 spreading actions with standard battery
Charging time ca.	approx. 1.5 h / 4.1 kWh approx. 2 h / 6.1 kWh approx. 2.5 h / 8.2 kWh	approx. 1.5 h / 4.1 kWh approx. 2 h / 6.1 kWh approx. 2.5 h / 8.2 kWh	approx. 1.5 h / 4.1 kWh approx. 2 h / 6.1 kWh approx. 2.5 h / 8.2 kWh
Charging system	230 V integrated charger on the machine	230 V integrated charger on the machine	230 V integrated charger on the machine
Electro-hydraulic unit			
Power electric motor	11.7 kW / 48 V (variable speed)	11.7 kW / 48 V (variable speed)	11.7 kW / 48 V (variable speed)
Hydraulic system	110 bar / 32 l/min (integrated load sensing)	110 bar / 32 l/min (integrated load sensing)	110 bar / 32 l/min (integrated load sensing)



© Aebi Schmidt Group | www.aebi-schmidt.com

Aebi Schmidt Holding AG | CH-8050 Zurich, Switzerland

All rights reserved. Technical data is subject to change.
Illustrations are not binding. Errors and amendments excepted.

Document created on
29 AUG 2024

 **aebi schmidt**
group